

Operating instructions

Commercial refrigerator

GB

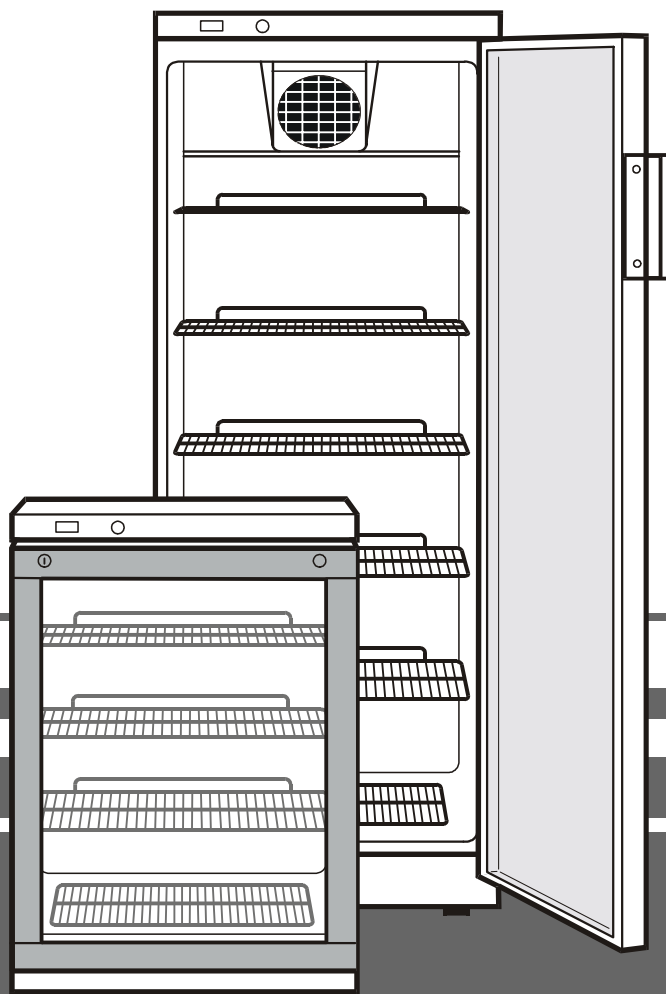

7080 347-00

FKS / UKS 1102

Safety instructions and warnings

- To prevent injury or damage to the unit, the appliance should be unpacked and set up by two people.
- In the event that the appliance is damaged on delivery, contact the supplier immediately before connecting to the mains.
- To guarantee safe operation, ensure that the appliance is set up and connected as described in these operating instructions.
- Disconnect the appliance from the mains if any fault occurs. Pull out the plug, switch off or remove the fuse.
- When disconnecting the appliance, pull on the plug, not on the cable.
- Any repairs and work on the appliance should only be carried out by the customer service department, as unauthorised work could prove highly dangerous for the user. The same applies to changing the mains power cable.
- Do not stand on the plinth, drawers or doors or use them to support anything else.
- Do not let children play with the appliance, e.g. do not allow them to sit in the drawers or swing on the doors.
- Do not consume food which has been stored for too long, as it could cause food poisoning.
- If you have a lockable appliance, do not keep the key near the appliance or within reach of children.
- Do not store explosives or sprays using combustible propellants such as butane, propane, pentane etc. in the appliance. Electrical components might cause leaking gas to ignite. You may identify such sprays by the printed contents or a flame symbol.
- Do not allow naked flames or ignition sources to enter the appliance. When transporting and cleaning the appliance ensure that the refrigerant circuit is not damaged. In the event of damage, make sure that there are no ignition sources nearby and keep the room well ventilated.
- Do not use electrical appliances inside the appliance.

Disposal notes

The packaging is made of recyclable materials.

- Corrugated board/board
- EPS moulded parts
- Polythene sheets
- Polypropylene straps

- Please return the packaging material to an official collection point.
- Do not dispose of discarded appliances with bulk refuse.
- Disable discarded appliances by removing the plug and cutting through the connection cable. Render the catch unusable so that children cannot become trapped inside.
- Ensure that the refrigerant circuit is not damaged when the appliance that is no longer needed is taken away for disposal.
- Details of the refrigerant used can be found on the type plate.
- Information on collection dates or collection points can be obtained from the waste disposal authorities or local council.

Setting up

- Avoid positioning the appliance in direct sunlight or near cookers, radiators and similar sources of heat.
- The floor on which the appliance stands should be horizontal and level. Compensate for uneven floors with the adjustable feet.
- Always ensure that there is good ventilation and that the outward flowing air is able to escape.
- Standard EN 378 specifies that the room in which you install your appliance must have a volume of 1 m³ per 8 g of R 600a refrigerant used in the appliance, so as to avoid the formation of inflammable gas/air mixtures in the room where the appliance is located in the event of a leak in the refrigerant circuit. The quantity of refrigerant used in your appliance is indicated on the type plate on the inside of the appliance.

Connecting to the mains

Power supply (a.c.) and voltage at the operating point must comply with the details on the type plate, which is located in the refrigerator compartment on the left-hand side. The socket must be fused with a 10 A fuse or higher, it must be away from the rear of the appliance and must be easily accessible.

Connect the appliance with a properly earthed fused plug and socket only.

The wires in the mains lead are coloured in accordance with the following code: green/yellow = earth, blue = neutral, brown = live. **Warning! This appliance must be earthed.**

Dimensions

Gross capacity (see type plate)	Height	Width	Depth
FKS/UKS 180 l (174 l)	884	602	600
FKS/UKS 260 l (252 l)	1215	602	600
FKS/UKS 360 l (352 l)	1589	602	600

Switching the appliance on and off

You are recommended to clean the appliance before switching it on for the first time (see "Cleaning"). The appliance is delivered ready for use and wired for normal operation. When it is connected up (plugged into an approved wall socket) the appliance is ready for operation.

To switch the appliance off: pull out the mains plug or remove/unscrew the fuse.

Setting the temperature

Using a coin, turn the arrow on the temperature control to a setting between "1" and "7".

Setting "1" = highest temperature

Setting "7" = lowest temperature

Cooling

This appliance can be used for chilling all types of drinks and food. The grid shelves can be moved to accommodate different height bottles or packages. To remove the shelves the door must be opened wider than 90°.

High-percentage alcohols should be tightly sealed and stored upright.

The ventilation slots on appliances with recirculated air fans on the inside must not be covered.

NB: This commercial appliance is suitable for almost universal use. When storing highly sensitive goods such as medicines etc., we recommend installing a temperature monitor unit.

Interior light

The light consists of a fluorescent tube with an integrated starter and is located at the top of the interior.

To change the tube:

- lever out the cover panel on the lamp housing at the front and remove downwards.
- Turn the tube 90° and pull out downwards. Insert a new tube and turn 90°.
- Replace the cover panel by inserting at the back and clicking into place at the front.

If the interior light still does not work after you have changed the bulb, please consult your nearest customer service point.

Shutting your appliance down

If your appliance is to be shut down for any length of time, switch it off and disconnect the plug or remove the fuse. Clean the appliance and leave the door open in order to prevent unpleasant smells.

Defrosting

The refrigerator compartment defrosts automatically.

Ensure that the water can flow without hindrance through the drain hole (see "Cleaning").

A layer of frost or ice can form on the cooling elements when the appliance has been operating at the coldest setting for a long time. If a layer of ice has formed, the cooling elements should be defrosted and the inside surfaces cleaned.

Remove the food from the appliance and store in a cool place. Leave the door of the appliance open while defrosting. After defrosting mop up the remaining water and clean the appliance.

Do not use any mechanical devices or other artificial aids for defrosting other than those recommended by the manufacturer.

Cleaning

Before cleaning always switch off the appliance. Pull out the mains plug or remove/unscrew the fuse.

Clean the inside, equipment parts and outer walls with lukewarm water and a little detergent. Do not use abrasive or acid cleaners or chemical solvents.

Do not use steam cleaners because of the risk of injury and damage.

- Ensure that no cleaning water penetrates into the electrical components or ventilation grille.
- Dry all parts well with a cloth.
- The dust should be removed from the refrigeration unit and heat exchanger - metal grid at the back of the appliance - once a year.
- Clean the drain hole in the refrigerator compartment with a thin object, e.g. cotton swab or the like.
- Do not damage or remove the type plate on the inside of the appliance. It is very important for servicing purposes.

Malfunctions

Your appliance is designed and manufactured for a lengthy, reliable operating life with no malfunctions. If a malfunction nonetheless occurs during operation, check whether it is due to an operating error. Please note that even during the warranty period the resultant servicing costs in this case will have to be borne by the owner.

You may be able to rectify the following faults by checking the possible causes yourself:

- **Appliance does not function:**
 - Is the appliance switched on?
 - Is the plug correctly fitted in the mains socket?
 - Is the socket fuse intact?
- **Loud running noise:**
 - Is the appliance set up firmly on the floor?
 - Does the appliance cause nearby items of furniture or objects to vibrate? Please note that noises caused by the refrigerant circuit cannot be avoided.
- **The temperature is not low enough:**
 - Is the temperature setting correct (see "Setting the temperature")?
 - Does the separately installed thermometer show the correct reading?
 - Is the ventilation system working properly?
 - Is the appliance set up too close to a heat source?

If none of the above causes apply and you cannot rectify the fault yourself, contact the nearest customer service department stating the type of appliance ①, index ② and service number ③ as indicated on the type plate. The type plate is located in the refrigerator compartment on the left-hand side.

①		②	
■■■■■ Index ■■■ / ■■■			
Service-Nr. / No. Service: ■■■■■■ - ■■■		③	
KLASSE	BRUTTOINHALT	NUTZINHALT	GES / R / G / KE / BIO
CLASSE	GROSS CAPACITY	NET CAPACITY	TOT / R / F / CE / BIO
CLASSE	VOLUME BRUT	VOLUME UTILE	TOT / R / C / CA / BIO
CLASSE	CAPACIDAD BRUTA	CAPAC. UTIL.	TOT / F / C / BO / BIO
TYPE	GEFRIERVERMOGEN		
TYPE	FREZING CAP.		
TYPE	POUV. DE CONGEL.		
TYPE	CAPAC. CONGELADORA		
R ■■■■ ■■■■			
AC ■■■■ V ■■■ ■■■ W			

Changing over door hinges

- Close the door and unscrew the hinge bracket ①.
- Pull the door out at the bottom and lift off.
- Unscrew the hinge pin ② from the hinge bracket ① and screw into the adjacent retaining hole.
- Unscrew hinge pin ③ and screw in on opposite side.
- Transfer door handle and plugs to the other side.
- Lift off the cover ④ and seal the exposed retaining holes on the other side with it.
- Mount door on hinge pin ⑤ and close.
- Insert hinge bracket ① in lower door mounting and screw onto plinth.

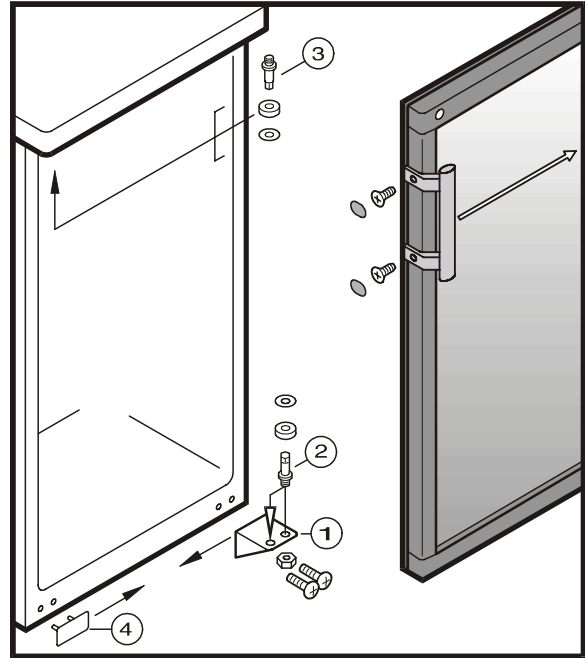

Replacing the door lock

