

# LIEBHERR

## Use and Care Manual

For Wine Cooler

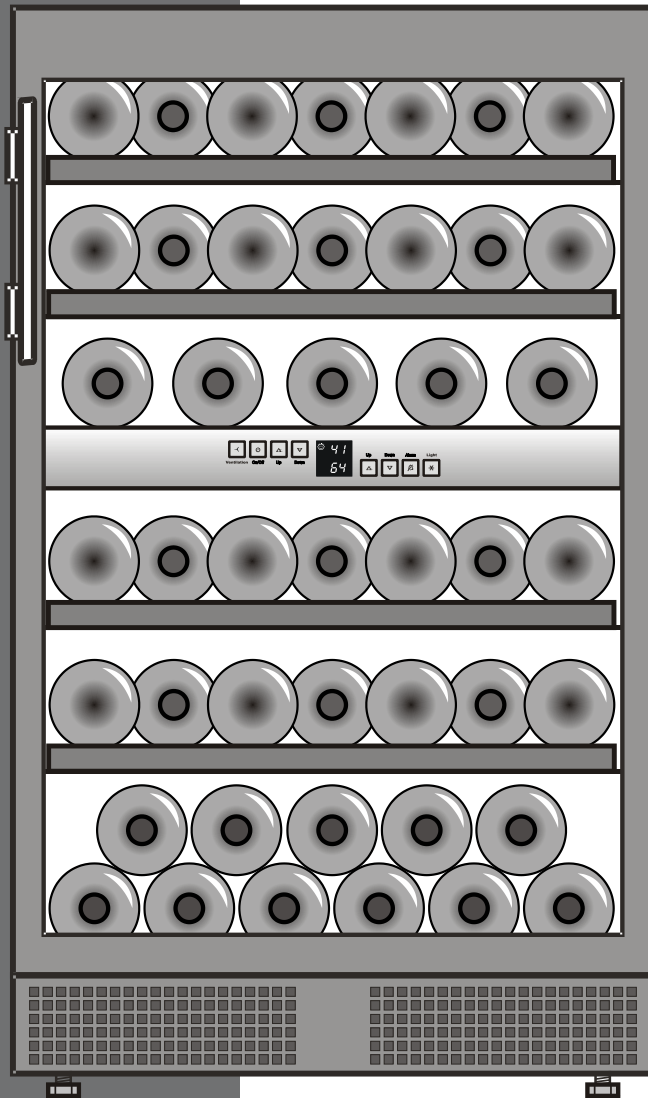

WU 40  
7081 209-00

## **Thank you for your trust**

Congratulations on your purchase of this wine cooler. In buying this product, which is distinguished by its perfect user-friendliness, impeccable reliability and high quality, you have chosen a top-of-the-line appliance. We wish you a lot of pleasure with your new wine cooler - and a lot of enjoyment from your wines.

The features on your appliance have been designed to ensure maximum convenience - day in, day out.

This appliance has been manufactured with recyclable materials using an environmentally friendly process, so together we're making an active contribution to the preservation of our environment.

Please read the information in the operating instructions carefully to become familiar with all the benefits of your new appliance.

We know you will be pleased with your new appliance.

### **Additional benefits**

- CFC-free
- Energy-optimized refrigerant circuit
- Energy-efficient insulation
- Low energy consumption
- User-friendly electronic controls
- Display of functions switched on
- Temperature can be controlled within climate rating range, regardless of room temperature
- Big capacity
- Variable and practical features
- Audible door open alarm
- Easy to clean
- Door hinges can be changed over

## **The fewer the grapes produced in an area, the better the wine**

Poor, well-drained soils are best for good wines. The properties of the soil influence the vitality of the vine, which in turn affects the quality of the grape. Climate is another factor that is important for wine. Light and air humidity are important for the development of the flavor of the wine.

## **The right environment for your wines**

A vine is an extremely sensitive plant. From the time it is planted to its maturing period and the time the grapes are harvested and the wine is made, it is dependent on three factors: light, air humidity and ambient temperature. This sensitivity continues even after the wine is bottled. To allow the flavor of the wine to fully develop or to preserve the excellent aroma, the wine has to be stored perfectly. Your wine cooler offers the best conditions for this.

# TABLE OF CONTENTS

---

Keep these operating instructions in a safe place and pass them on to the next owner, where applicable.

<b>Contents</b>	<b>Page</b>
Safety .....	4
Disposal of Old Appliance .....	4
Important Safety Information .....	4
Electrical Safety .....	5
Unpacking .....	6
Safety Instructions and Warnings .....	6
Disposal of Carton .....	6
Safety Regulations .....	7
The Under-Counter Wine Cooler .....	7
Installation .....	8
Fitting Dimensions .....	8
Installation and Fitting .....	8
Reversing the Door Hinges .....	9
Operation .....	10
Operating and Control Elements .....	10
Turning the Appliance ON and OFF .....	10
Setting the Temperature .....	10
Ventilation Button .....	10
Additional Functions .....	11
Audible Warning Signal .....	11
Wine Cooler Compartment .....	12
Interior Lighting .....	12
Additional Features .....	12
Pull-out Racks .....	12
Labels .....	12
Air Exchange with Activated Carbon Filter .....	13
Storage Diagram .....	13
Safety lock .....	13
Defrosting/Cleaning .....	14
Defrosting .....	14
Cleaning .....	14
Troubleshooting .....	15
Customer Service .....	15
Appliance Information .....	15
Warranty .....	16

## **IMPORTANT**

*All types and models are subject to continuous improvement. The manufacturer reserves the right to make modifications in the shape, equipment and technology.*

# SAFETY

---

Read and follow all the safety rules and operating instructions before using this appliance. Save these instructions for future reference. Throughout this instruction manual are specific Important instructions, Cautions and Warnings.

## DANGER

**Danger indicates a hazard which will cause serious injury or death if precautions are not followed.**

## WARNING

**Warning indicates a potentially hazardous situation which, if not avoided, could result in death or serious injury.**

## CAUTION

**Caution indicates a potentially hazardous situation which, if not avoided, may result in minor or moderate injury.**

### **IMPORTANT**

*This highlights information that is especially relevant to a problem-free installation.*

## **Disposal of Old Appliance**

Be sure to follow your local requirements for disposal of appliances. Discarded appliances can be dangerous.

## DANGER

**Risk of child entrapment. Before you discard old appliances:**

- **Be sure to follow your local requirements for disposal of appliances. Discarded appliances can be dangerous.**
- **Remove the doors.**
- **Leave the shelves in place so that children may not easily climb inside.**
- **Cut off the prongs from the power cable plug and discard them.**
- **Cut off the power cable from the discarded refrigerator. Discard separately from the refrigerator.**

**Following these instructions reduces the possibility of causing personal injury, especially to children playing.**

**Contact the trash collection agency in your area for additional information.**

## **Important Safety Information**

This appliance is intended for domestic use only. Use the appliance only for its intended purpose; the storage of food products. Follow the cautions and safety warnings throughout this instruction manual including the following:

- To prevent injury to you or damage to the unit, the appliance should be unpacked and set up by two people.
- If the appliance is damaged on delivery, contact the supplier immediately before connecting to the power source.
- To guarantee safe operation, ensure that appliance is set up and connected as described in these operating instructions.
- Disconnect the appliance from the power source if a fault occurs. Pull out the plug, turn off or disable the power source.
- When disconnecting the appliance, use the plug. Do not pull on the cable.
- Any repairs and work on the appliance should only be performed by the customer service department. Unauthorized work may be dangerous to the user. Changing the power source cable should only be done by the customer service department.
- Do not store explosives or sprays using combustible propellants such as butane, propane, pentane, etc. in the appliance. Electrical components might cause leaking gas to ignite. You may identify such sprays by the printed contents or a flame symbol.
- Do not use electrical appliances inside the appliance.
- Do not allow children to play with the appliance. Children must not climb, sit or stand on the racks or door.

- To prevent possible injury due to an electrical shock, be sure to disconnect the power cord or turn off the circuit breaker before replacing the interior light or cleaning the appliance.
- To prevent possible injury due to broken glass, use hand protection when replacing the interior light.
- To avoid injury or damage to the appliance, do not use steam cleaning equipment to clean the appliance.
- Do not operate the wine cooler in the presence of explosive fumes.
- In the event of a power outage, minimize opening the door.
- To protect the wine cooler from possible damage, allow the appliance to stand 1/2 to 1 hour in place before turning the electricity on. This allows the refrigerant and system lubrication to reach equilibrium.

## **Electrical Safety**

Connect this appliance to a 110-120 VAC, 15 amp circuit that is controlled by a circuit breaker or fuse. This appliance should have its own separate grounded circuit. Do not use an extension cord.

The power cord is equipped with a three-prong (grounding) plug for your protection against possible shock hazards. To maintain this protection:

- Do not modify the plug by removing the round grounding prong.
- Do not use a two-prong adapter. Where a two-prong wall receptacle is encountered, contact a qualified electrician and have it replaced with a three-prong receptacle in accordance with all local codes and ordinances.
- Do not use a power cord that is frayed or damaged.

# UNPACKING

---

## Safety Instructions and Warnings

### CAUTION

**To avoid risk of personal injury or property damage, have two people unpack and move this appliance into place.**

### CAUTION

**Protect the finished floor surface before you uncrate the unit.**

Avoid placing the appliance in direct sunlight or near the stove, range top, radiators and similar heat sources.

The floor under the appliance should be flat and level.

Keep the appliance out of the weather. The ventilation grille should not be obstructed. Always ensure there is good ventilation in front of the appliance.

As soon as you uncrate the unit:

- Examine the unit and packaging for shipping damage. Contact the carrier immediately if you suspect there is any damage.
- Note the type (model number), index, appliance / serial number, date of purchase and where purchased on the spaces provided in the back of this manual.

## Disposal of Carton

The packaging is designed to protect the appliance and individual components during moving and is made of recyclable materials.

- Corrugated board/board
- Molded polystyrene (foamed, CFC-free polystyrene)
- Polythene bags and sheets
- Polypropylene straps

### WARNING

**Keep packaging materials away from children. Polythene sheets and bags can cause suffocation!**

- Please take the packaging material to your local recycling facility.

## Safety Regulations

The appliance is designed to cool and store wine and beverages. It is designed as a household appliance.

The appliance is set to operate within specific ambient temperature limits according to its climate rating. These temperature limits should not be exceeded. The correct climate rating for your appliance is indicated on the model plate.

This is explained as follows:

Climate Rating	Set for Ambient Temperatures of
SN	50°F to 90°F (10°C to 32°C)
SN-T	50°F to 109°F (10°C to 43°C)
N	61°F to 90°F (16°C to 32°C)
ST	61°F to 100°F (16°C to 38°C)
T	61°F to 109°F (16°C to 43°C)

- The refrigerant circuit has been tested for leaks.
- The appliance complies with current safety regulations UL250 and CSA C22.2 #63.

We recommend cleaning the appliance before turning it on for the first time. See **Cleaning**. Turn on the appliance several hours before loading it.



### WARNING

**Do not allow children to play with the appliance. Children must not climb, sit or stand on the racks or door. Failure to follow these instructions may result in death or serious injury.**

## The Under-Counter Wine Cooler - Figure 1

Wines only develop their full flavor and aroma when they are at the right temperature for drinking. In your wine cooler, wines can be brought slowly and evenly to the ideal drinking temperature. Red wines and white wines can be stored at the same time at the optimal drinking temperature in two separately adjustable temperature zones.

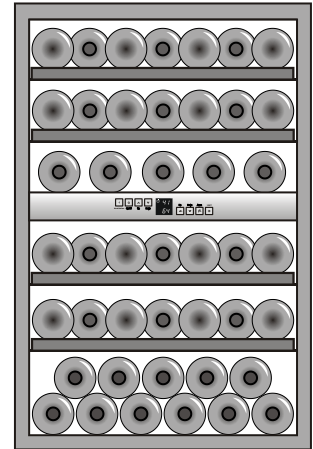
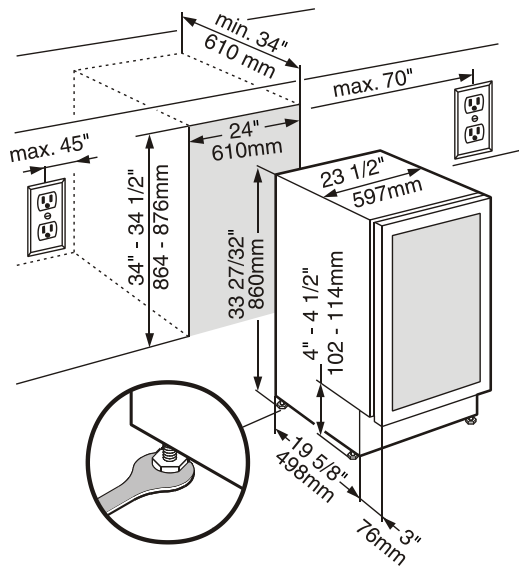

Figure 1

# INSTALLATION

## Fitting Dimensions - Figure 2



**Figure 2**

\* Overall height can be increased by 2 inch (50 mm) by adjusting the feet.

Adjust to recess height using the four adjustable feet on the underside of the appliance.

Put the electrical outlet in a location where it does not interfere when the wine cooler is placed into its recess.

### IMPORTANT

*The fitting dimensions are actual, allow for additional clearance for sliding the wine cooler into its recess based on how you chose the final installation to look. Make sure your installation does not block the ventilation grille. (Figure 2a).*

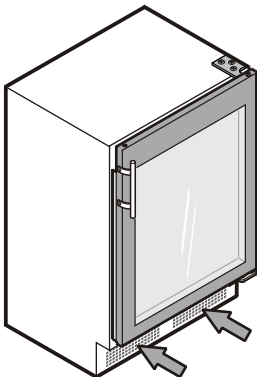

**Figure 2a**

## Installation and Fitting - Figure 3

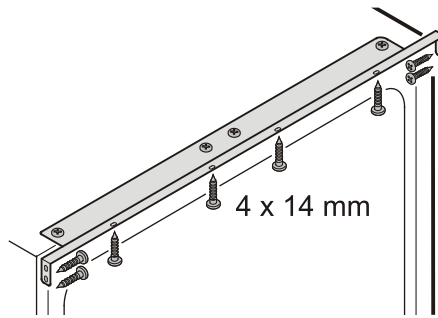

**Figure 3**

1. Connect the appliance to the dedicated outlet.
2. Slide the appliance into the recess.
3. Secure the appliance in the recess using 4 x 14 mm screws.

The screws can be installed into the counter or into the cabinet or frame on the sides of the wine cooler, or in any combination. Four screws must be used.

The appliance is adapted with a door opening limiter. The maximum opening angle is 105°.

### ⚠ WARNING

**The wine cooler must be attached to the cabinet or counter before it is used.**



# INSTALLATION

## Reversing the Door Hinges - Figure 4

### CAUTION

To prevent possible injury from an electrical shock, be sure to disconnect the power cord or turn OFF the circuit breaker before performing the following steps.

### CAUTION

To avoid injury from sharp edges, wear protective gloves before performing the following steps.

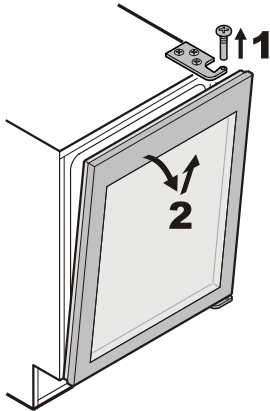

1. Unscrew hinge pin.
2. Lift off the door.
3. Pull out sleeve and reassemble.
4. Unscrew upper hinge plate, turn it 180° and screw on the opposite side.
5. Unscrew lower hinge plate.
6. Remove screws.

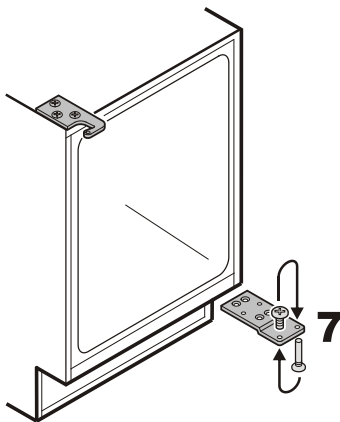
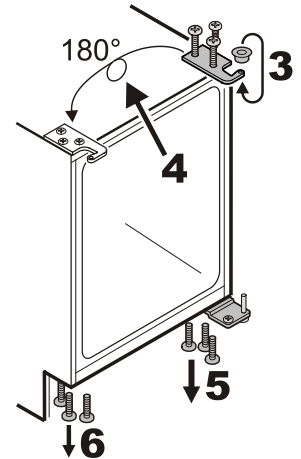

7. Transfer both pins of the hinge plate to the opposite side.
8. Insert screws again.
9. Reassemble lower hinge plate on the left side of the unit.

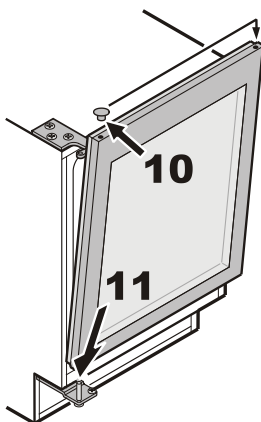
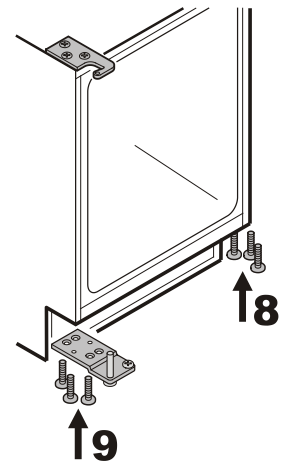

10. Transfer plug to the opposite side of the door.
11. Suspend door on hinge pin and close.
12. Insert hinge pin and tighten.
13. Transfer handle and plugs to the opposite side.

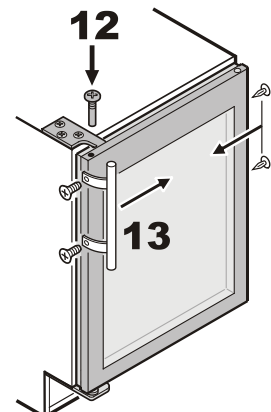

Figure 4

# OPERATION

## Operating and Control Elements - Figure 5



Figure 5

1. Lower compartment temperature display
2. Upper compartment temperature display
3. Lower compartment temperature setting buttons
4. Upper compartment temperature setting buttons
5. Alarm ON/OFF button
6. Interior light ON/OFF button
7. Childproof Lock
8. ON/OFF button
9. Ventilation button

## Turning the Appliance ON and OFF - Figure 6

Clean the appliance before turning it on for the first time. See **Cleaning**. Connect the appliance to the dedicated outlet - the appliance is turned on. The alarm will sound when the appliance is turned on for the first time and when the appliance is warm. Press the Alarm button to turn it off. The temperature display will also flash.

- **To turn the appliance off:** Keep the ON / OFF button pressed for three seconds so that the temperature display goes out.
- **To turn the appliance on:** Press the ON / OFF button until the display lights up.



Figure 6

## Setting the Temperature - Figure 7

The temperature of both compartments can be set separately.

To reduce the temperature: Press the ▼ “DOWN” button;

- on the left for the upper compartment, on the right for the lower compartment.
- To increase the temperature: Press the ▲ “UP” button.
- While you are entering the temperature, the set temperature will flash on the display.
  - You can change the settings in increments of 1°F (1°C) by briefly pressing the button again. The electronic controls will switch over automatically about five seconds after the last time you pressed the button. The actual temperature displays.



Figure 7

If *F0* or *F1* appears in the display, the appliance has a fault. Contact your nearest customer service representative, indicate the **type of appliance, index and Appliance / serial number**.

## Ventilation Button - Figure 8

Should you wish to use the wine cooler to store wine for long periods of time, activate the “Ventilation” button. The light in the button comes on and the ventilation function is active. Then the climate which corresponds to that of a wine cellar is achieved inside the wine cooler. Bottle corks are prevented from drying out due to an increased level of humidity.

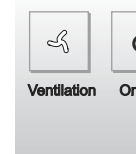

Figure 8

## Additional Functions - Figures 9 - 12

In setup mode you can set the **Childproof Lock**, adjust the **brightness of the display** and choose the **unit of temperature** for the display in degrees Fahrenheit or degrees Celsius. The childproof lock is designed to protect the appliance from being switched off accidentally by children.

Activating set-up mode:

- Press the ventilation button for approximately five seconds
    - the fan button flashes - the display shows  $\zeta$  for childproof lock.
- Note:** the value to be altered flashes.

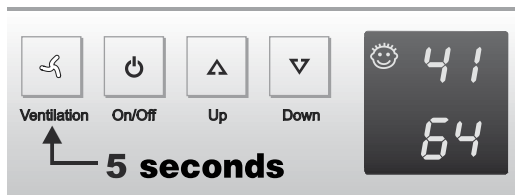



Figure 9

- Select the required function by pressing the  $\blacktriangle/\blacktriangledown$  (UP/DOWN) button:
    - $\zeta$  = **Childproof Lock**,  $h$  = **brightness** or  $\square$  = **changing the temperature display**.
  - Now select ON or OFF by pressing the ventilation button briefly:
    - For  $\zeta$  = childproof lock, press the  $\blacktriangle/\blacktriangledown$  (UP/DOWN) button to select
      - $\zeta$  1 = childproof lock on or
      - $\zeta$  0 = childproof lock off and acknowledge with the fan button.
- When the symbol  is lit, the childproof lock is activated.

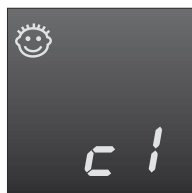

Figure 10

For  $h$  = brightness, press  $\blacktriangle/\blacktriangledown$  (UP/DOWN) button to select  
 $h$  1 = minimum to  
 $h$  5 = maximum brightness and acknowledge with fan button.

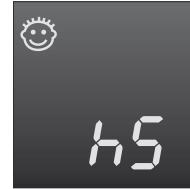

Figure 11

For  $\square$  = unit of temperature, press  $\blacktriangle/\blacktriangledown$  (UP/DOWN) button to select  $^{\circ}\text{C}$  = to display degrees Celsius,  $^{\circ}\text{F}$  = to display degrees Fahrenheit for temperature display and acknowledge with fan button.



Figure 12

Exit set-up mode:

- Exit the set-up mode by pressing the **ON/OFF** button; after two minutes the electronic system switches over automatically. The normal operating mode is activated again.

## Audible Warning Signal - Figure 13

The audible warning signal helps to protect your wines against excessive temperature fluctuations.

- The audible warning signal sounds when the door is open for longer than about 180 seconds. The audible warning device is turned off by pressing the **Alarm** button.
- The audible warning signal sounds when the interior gets too warm or too cold. The temperature display will also flash. The audible warning device is turned off by pressing the **Alarm** button. The temperature display will continue to flash until the cause of the alarm has been rectified.

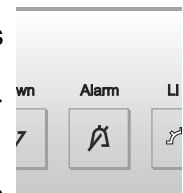

Figure 13

# WINE COOLER COMPARTMENT

## Interior Lighting - Figures 14 - 15



The interior light emits class 1M laser radiation. Do not look directly at light or through any optical instruments when the light defuser is removed. Severe eye injury can occur.

A lightbar is integrated into the upper and lower compartments.



**Figure 14**

The interior lights can be turned on and off using the **Light** button, and the brightness of the lighting can be adjusted.

- Press the **Light** button. The indicator lamp in the switch will light.
- Then press and hold the **Light** button and at the same time press the temperature setting buttons for the lower compartment to increase or decrease the brightness.  
▼ **DOWN** = darker, ▲ **UP** = brighter.

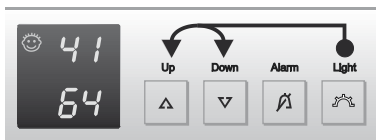

**Figure 15**

## Additional Features

### Pull-out Racks - Figure 16

The pull-out racks allows bottles of wine to be viewed and removed more easily. The control element panel shelf cannot be removed.

### Labels

The appliance is supplied with a label holder with labels for each rack. Use these to label the type of wine stored on each shelf. Use a soft pencil on the labels so that you can erase it again when necessary. Additional labels can be obtained from your Liebherr Dealer or Distributor.

**Fitting:** Click the label holder into place and slide the label in from the side.



**Figure 16**

# WINE COOLER COMPARTMENT

## Air Exchange with Activated Charcoal Filter - Figure 17

The way in which wines continue to mature depends on the ambient conditions. The quality of the air is therefore decisive for preserving the wine. Your Liebherr wine cooler is equipped with an activated charcoal filter in the interior rear wall of both the upper and lower compartments.

We recommend you replace the filter at least once a year. Filters can be obtained from your Liebherr Dealer or Distributor.

**Removing the filter:** Hold the filter by the handle. Turn it 90° to the left or right and remove.

**Reinstalling the filter:** Insert with the handle in a vertical position. Turn it 90° to the left or right until it clicks into place.

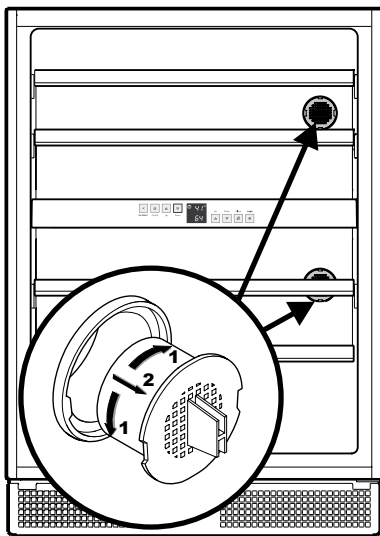

Figure 17

## Storage Diagram - Figure 18

It is possible to store up to 44 Bordeaux bottles of 750 ml each in your wine cooler.

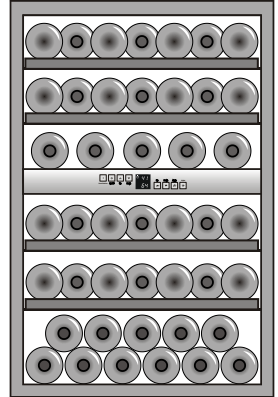

Figure 18

## Safety Lock - Figure 19

The lock in the appliance door is equipped with a safety mechanism.

### Locking the appliance:

- Insert the key and push as shown by arrow **1**.
- Turn the key 90° counterclockwise **2**.

To unlock the appliance, the procedure must be repeated in the same order; turning the key clockwise.



**Hold the key at all times. The lock cylinder is spring loaded and will eject the key if released from your grip.**

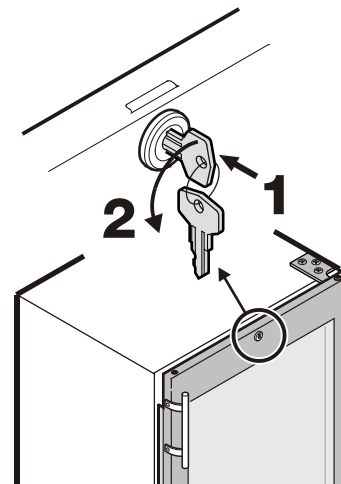

Figure 19

# DEFROSTING/CLEANING

## Defrosting

The wine cooler compartment defrosts automatically. The water that forms on the rear wall drains into a reservoir at the back of the appliance and evaporates automatically through the compressor heat.

## Cleaning



**WARNING**



- To prevent possible injury due to an electrical shock, be sure to disconnect the power cord or turn OFF the circuit breaker before replacing the interior light tube or cleaning the appliance.
- To avoid injury or damage, do not use steam cleaning equipment to clean the appliance.

Clean the appliance by hand with lukewarm water and a little detergent.

**DO NOT** use abrasive or scouring sponges. **DO NOT** use concentrated cleaning agents. **NEVER** use abrasive or acid cleaners or chemical solvents or steam cleaners.

- Ensure no cleaning water penetrates into the electrical components or ventilation grille.
- Dry all parts well with a cloth.
- Do not damage or remove the model plate on the inside of the appliance. It is very important for servicing your appliance.

Remove any dust from the outside of the ventilation grille (**Figure 20**) with a vacuum cleaner.

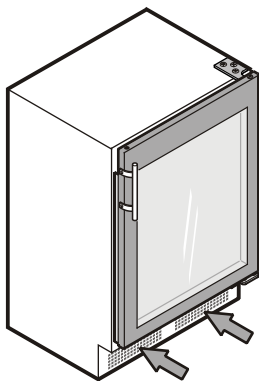

**Figure 20**

Keep your stainless steel looking new by cleaning with a good quality stainless steel cleaner or polish monthly. High quality stainless steel cleaners and conditioners are commercially available.

**DO NOT CLEAN WITH STEEL WOOL PADS or ABRASIVE PADS.** Do not use cleaners that are not for use on stainless steel, such as glass cleaners, tile cleaners or cleaners used to clean counter tops. These types of cleaners can damage the surface permanently.

Stainless steel that is exposed to chlorine gas and moisture may have some discoloration. This discoloration is normal. If your unit is used in this environment, clean and polish your stainless steel more often.

If the surface discolors or rusting appears, clean it quickly with a non-abrasive cloth and protect it. Always clean and polish in the direction of the grain and finish.

### **IMPORTANT**

*Mold can form on the bottles and labels depending on the type of adhesive used on the labels. This can be prevented by carefully cleaning any adhesive residues off the bottles.*

# TROUBLESHOOTING

Your appliance is designed and manufactured for a long life and reliable operation.

If a problem occurs during operation, check whether it is due to an operating error. Please note that even during the warranty period, some repair costs may be your responsibility.

You may be able to correct the following faults by checking the possible causes yourself:

Problem	Possible Cause and Remedy
Appliance does not work, display is off	<ul style="list-style-type: none"> <li>- Is the appliance turned on properly?</li> <li>- Is the power cord properly inserted in the outlet?</li> <li>- Is the circuit breaker or fuse in operating condition?</li> </ul>
The interior light does not come on	<ul style="list-style-type: none"> <li>- Is the appliance turned on?</li> <li>- Is the interior light turned on?</li> <li>- The interior light is defective. Contact your Liebherr Dealer or Representative.</li> </ul>
Loud running noise	<ul style="list-style-type: none"> <li>- Is the appliance placed firmly on the floor, or does the compressor cause nearby items of furniture or objects to vibrate? If necessary, move the appliance slightly, align by adjusting the adjustable feet, or adjust bottles.</li> </ul>
Motor seems to run too long	<ul style="list-style-type: none"> <li>- Is the ambient temperature too hot? See <b>Safety Regulations</b>.</li> <li>- Has the appliance been opened too often or left open too long?</li> </ul>
The temperature is not cold enough	<ul style="list-style-type: none"> <li>- Is the temperature setting correct? See <b>Setting The Temperature</b>.</li> <li>- Has an excessive amount of wine been placed in the appliance?</li> <li>- Does a separately installed thermometer show the correct reading?</li> <li>- Is the ventilation system working properly?</li> <li>- Is the appliance set up too close to a heat source?</li> </ul>
<i>F0</i> or <i>F1</i> appears in the display	The appliance has a fault. Contact your nearest customer service representative, indicate the type of appliance, index and appliance / serial number.

## Customer Service

If none of the above possible causes apply, and you can not rectify the fault yourself, contact your nearest customer service representative. Indicate the type (1) of appliance, service number (2) and the appliance / serial number (3) as indicated on the model plate. The model plate is located on the left-hand inside wall.

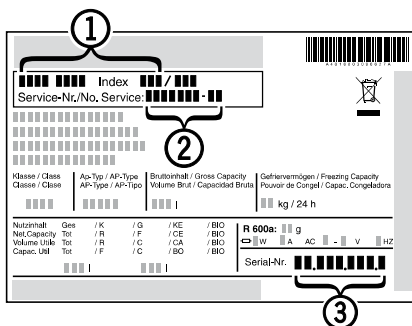

## Appliance Information

Record this information when the appliance is installed.

Type Designation: \_\_\_\_\_

Index: \_\_\_\_\_

Appliance / serial number: \_\_\_\_\_

Date of Purchase: \_\_\_\_\_

Where Purchased: \_\_\_\_\_

# WARRANTY

---

## LIEBHERR WARRANTY PLAN

### FULL TWO YEAR WARRANTY

For two years from the date of original purchase, your Liebherr warranty covers all parts and labor to repair or replace any part of the product which proves to be defective in materials or workmanship.

### FULL FIVE YEAR WARRANTY

For five years from the date of original purchase, your Liebherr warranty covers all parts and labor to repair or replace any components that prove to be defective in materials or workmanship in the sealed system. The "Sealed System" means only the compressor, condenser, evaporator, drier and all connecting tubing.

### LIMITED 6TH THROUGH 12TH YEAR WARRANTY

From the 6th through 12th year from the date of original purchase, your Liebherr warranty covers all parts that prove to be defective in materials or workmanship in the Sealed System (parts only).

### TERMS APPLICABLE TO EACH WARRANTY

All service provided by Liebherr under the warranty must be performed by authorized Liebherr service representatives, unless otherwise specified by Liebherr. Service will be provided in the home during normal business hours. This warranty applies only to products installed for normal residential use. Details regarding a non-residential warranty are available on request.

The warranty applies only to products installed in Canada and any one of the fifty states of the United States or the District of Columbia. This warranty does not cover any parts or labor to correct any defect caused by negligence, accident or improper use, maintenance, installation, service or repair, including but not limited to improper removal and reinstallation of the condensing unit.

**THE WARRANTIES DESCRIBED ABOVE ARE MADE EXPRESSLY IN LIEU OF ANY OTHER WARRANTIES, EXPRESSED OR IMPLIED, INCLUDING ANY IMPLIED WARRANTY OF MERCHANTABILITY OR FITNESS FOR A PARTICULAR PURPOSE, AND OF ANY OTHER OBLIGATION OR LIABILITY ON THE PART OF LIEBHERR. IN NO EVENT SHALL LIEBHERR BE LIABLE FOR SPECIAL, INCIDENTAL OR CONSEQUENTIAL DAMAGES ARISING FROM THE BREACH OF THESE WARRANTIES OR ANY OTHER WARRANTIES, WHETHER EXPRESS, IMPLIED OR STATUTORY.**

Some States do not allow the exclusion or limitation of incidental or consequential damages so the above limitation or exclusion may not apply to you. This warranty gives you specific legal rights and you may also have other rights which vary from State to State.

To receive parts and/or service and the name of the Liebherr authorized service representative nearest you, contact your Liebherr dealer or distributor or contact the Liebherr designated national service provider:

in the US: [Service-appliances.us@liebherr.com](mailto:Service-appliances.us@liebherr.com), or call 1-866-LIEBHER or 1-866-543-2437  
in Canada: [www.euro-parts.ca](http://www.euro-parts.ca), or call 1-888-LIEBHER, 1-888-543-2437.



## **For Service in the U.S.**

### **Liebherr Service Center**

Toll Free: **1-866-LIEBHER** or **1-866-543-2437**

Email: [Service-appliances.us@liebherr.com](mailto:Service-appliances.us@liebherr.com)

### **PlusOne Solutions, Inc.**

3501 Quadrangle Blvd, Suite 120

Orlando, FL 32817

## **For Service in Canada**

### **Liebherr Service Center**

Toll Free: **1-888-LIEBHER** or **1-888-543-2437**

[www.euro-parts.ca](http://www.euro-parts.ca)

### **EURO-PARTS CANADA**

39822 Belgrave Road

Belgrave, Ontario, N0G 1E0

Phone: (519) 357-3320

Fax: (519) 357-1326